

SLIDING DOOR & WINDOW

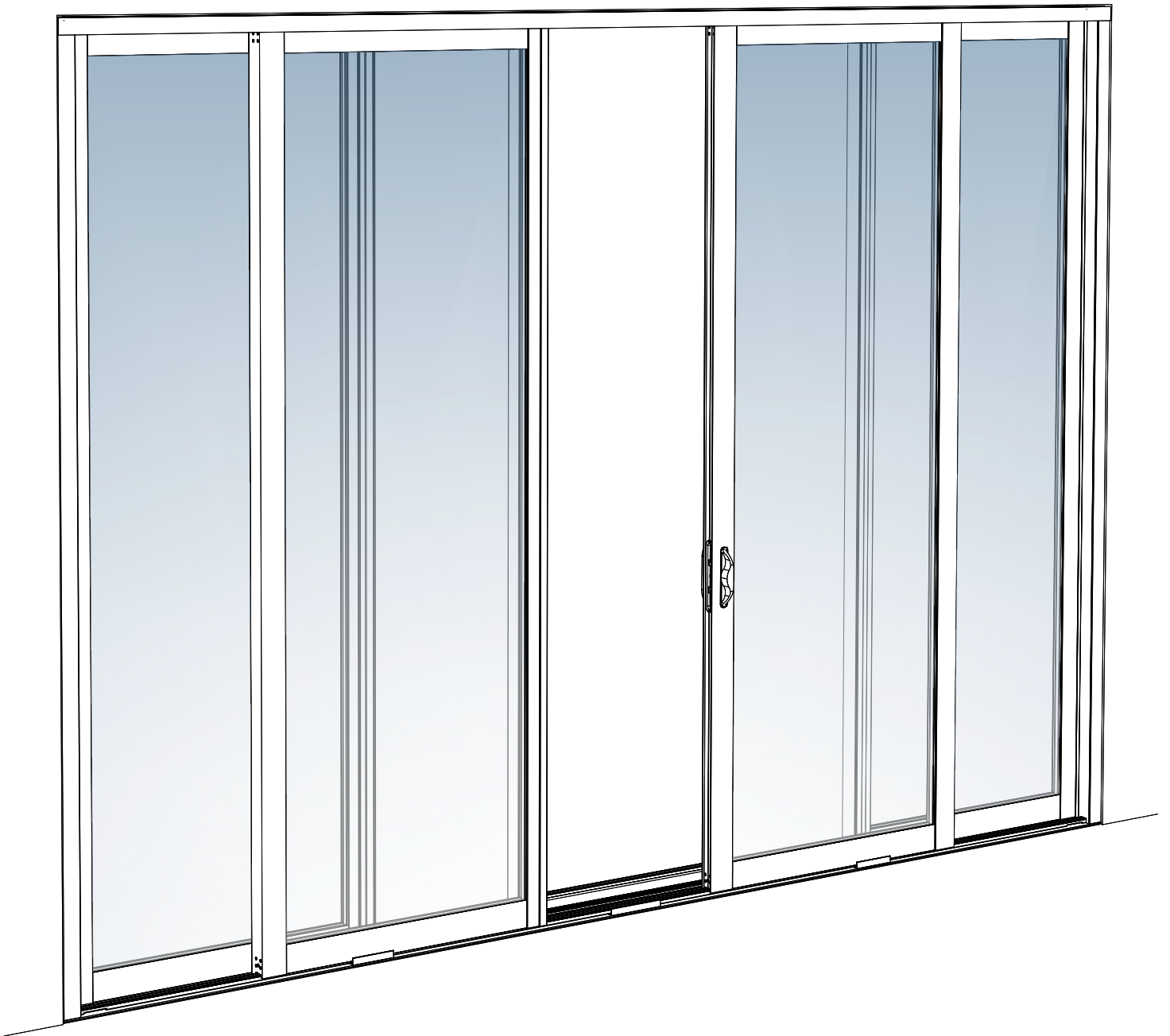

HSEQ

Wear the necessary personal protective equipment for product installation.

Take safety precautions when performing the activity.

Work tools must be used properly.

Check tools conditions before using them.

Keep order and cleanliness.

INTRODUCTION

A sliding glass door consists of panels which slide horizontally on its frame sill. Such panels are interlocked to ensure seal and run parallel to the opening plane.

Maintenance and proper use is important for the correct operation of the system, as well as for ensuring its service life and guarantee secure handling for the user and passersby.

Please read this guide and abide by use, cleaning and maintenance as indicated in this document.

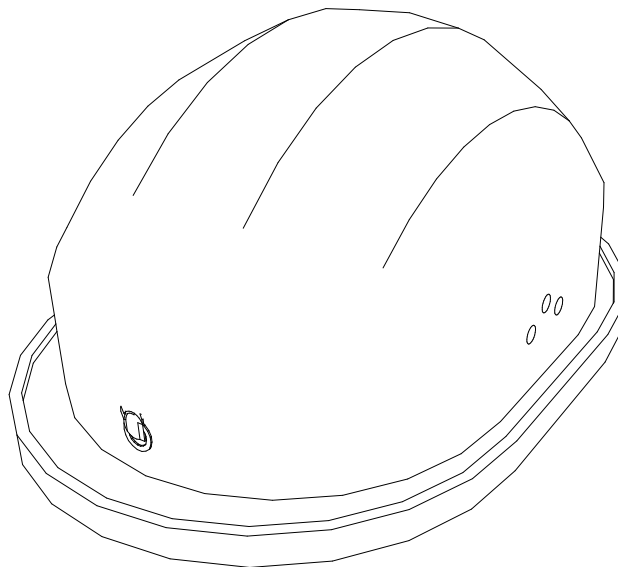

DEFINITIONS

- **Opening:** Aperture in a wall for the purpose of installing a door.
- **Jamb:** Vertical side members of the door's frame.
- **Sill:** Horizontal lower member of the door's frame.
- **Head:** Horizontal upper member of the door's frame.
- **Glass Stop:** Small section part for the sole purpose of fixing the glass panel. Not all doors have this part.
- **Panel:** Refers to the main actuating component of the door.

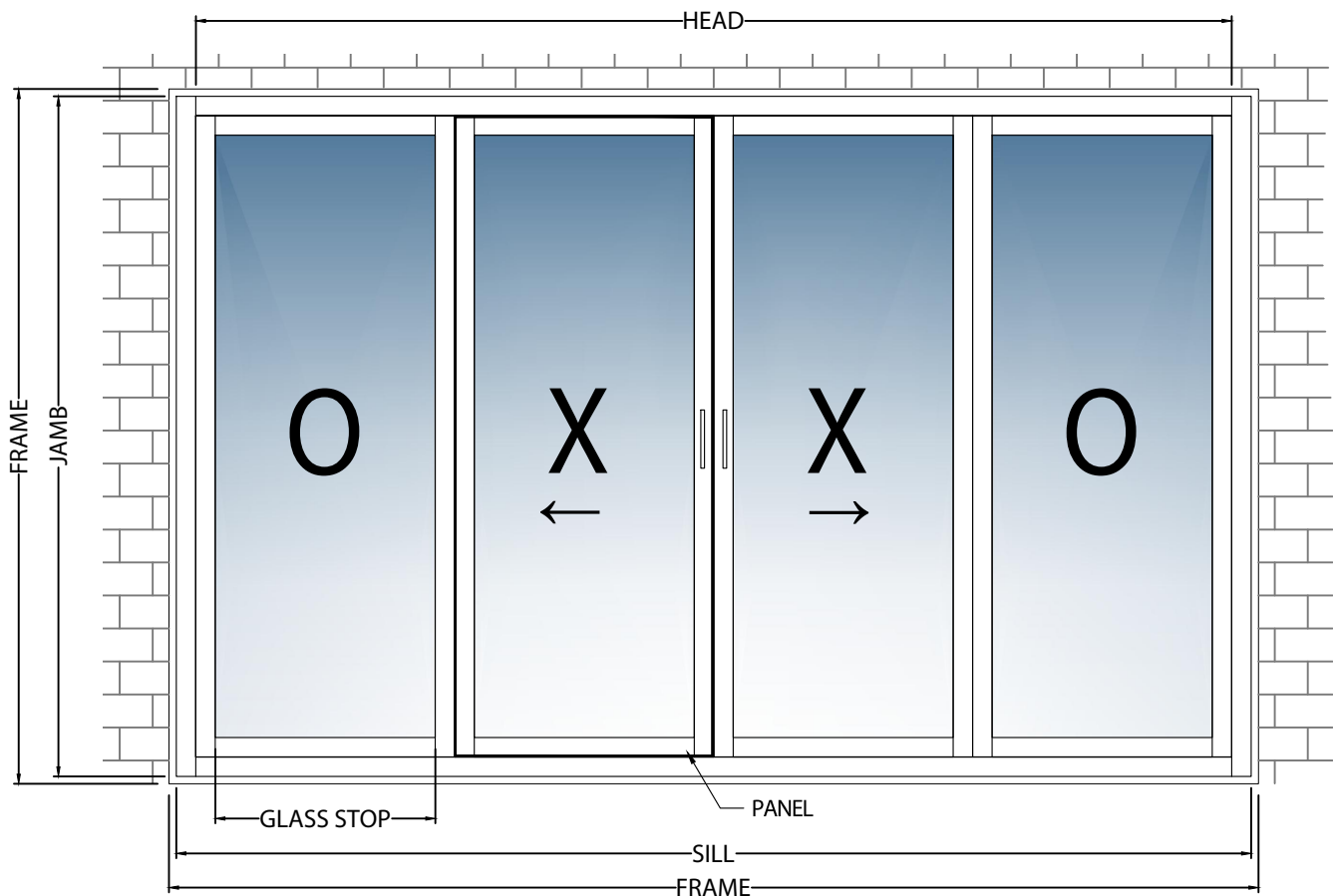

RECOMENDATIONS

- Don't remove the panel. If necessary, contact ESR.
- Verify there are no objects obstructing the rail track while opening the door or window.
- Verify that all mechanisms work properly.
- Clean thoroughly by removing dust or other particles from operating parts using a brush or compressed air.
- Preventive maintenance is necessary every 4 months. Parts such as hinges, pivots, closer, panic devices, flush bolts, screws and weatherstripping should be cleaned. Some parts should be lubricated if required.
- In case of damage replace parts.
- Consult ESR personnel to solve any questions.

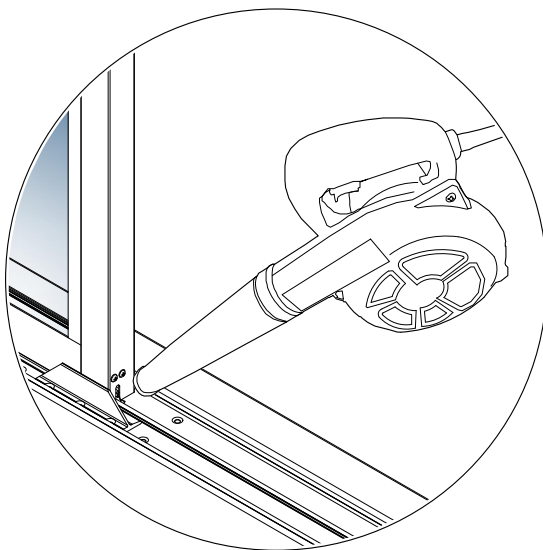

Avoid door handling during construction. If necessary, make sure to keep clean the door or window. Accumulation of construction materials might permanently damage some parts and speed up aging process of metals.



Keep receipt for warranty purposes.



*If is necessary remove panel, make sure to protect gasket from damage by securing it with tape long enough to remove it after panel installation:

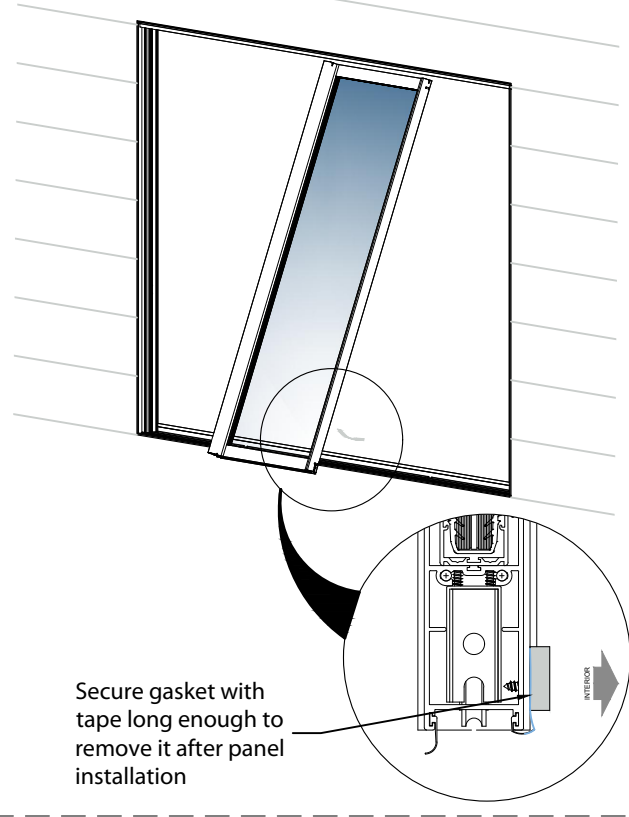

ALUMINUM MAINTENANCE

- Pressurized water must be used with moderate pressure and adequate distance to clean the door or window. Excessive pressure or proximity can compromise the integrity of the seals and product components. For a thorough cleaning use soft sponges or soft bristle brushes.
- The cleaning process should be done with uniform pressure and vertical or horizontal movements.
- Avoid the use of strong alkaline or acid cleaners. Do not use cleaning solutions containing trisodium phosphate, phosphoric acid, hydrochloric acid, hydrofluoric acid, perchloric acid, fluorides or similar components.
- Test cleaning solutions in a small spot to prevent staining.
- Maintain an appropriate ambient temperature (between 60 and 75 degrees Fahrenheit) while cleaning; cleaning at high temperatures might cause stains and damages.
- Avoid applying cleaning solutions at freezing point temperatures since condensation might take place.



Avoid direct contact with cement, concrete or abrasive compounds. Aluminum might and will suffer permanent damage if exposed.

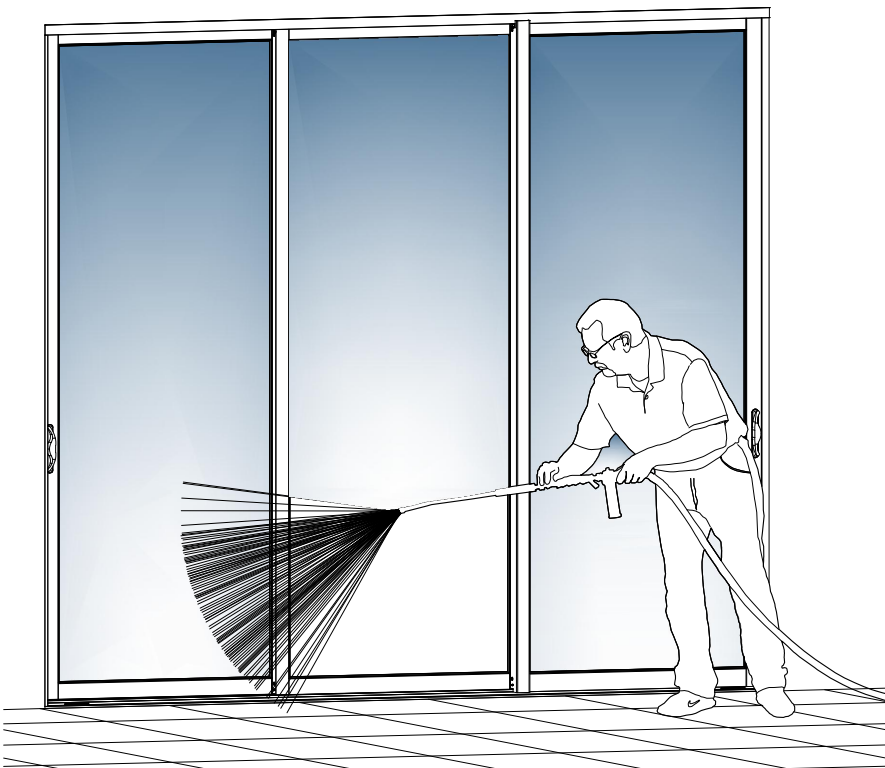

PVC MAINTENANCE

- Regularly clean off dust, dirt, and contaminants using a soft cloth or sponge. It's advisable to steer clear of strong cleaning agents that might damage the surface coating. Avoid using sharp tools or abrasive materials when cleaning.
- Do not use cleaning products containing organic solvents, petroleum, and its derivatives, such as methylethylketone, acetone, benzene or other aromatics like xylenes/toluene, and ethers.
- Test cleaning solutions in a small spot to prevent staining.
- Maintain an appropriate ambient temperature (between 60 and 75 degrees Fahrenheit) while cleaning; cleaning at high temperatures might cause stains and damages.
- Avoid applying cleaning solutions at freezing point temperatures since condensation might take place.



Avoid direct contact with cement, concrete or abrasive compounds. PVC may suffer permanent damage if exposed to abrasive products.

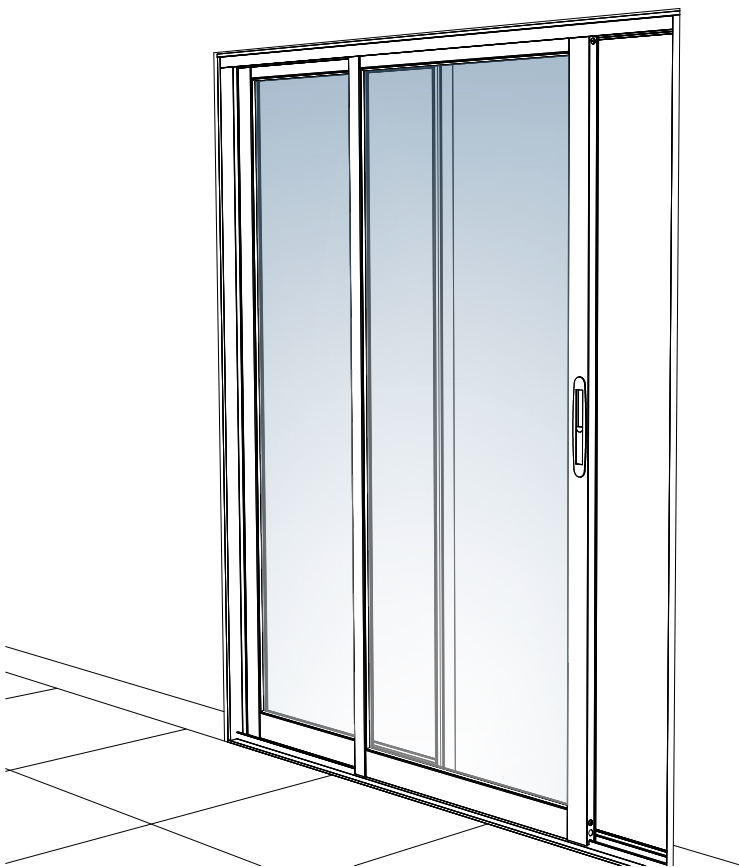

GLASS MAINTENANCE

- Pressurized water must be used with moderate pressure and adequate distance to clean the door or window. Excessive pressure or proximity can compromise the integrity of the seals and product components. For a thorough cleaning use soft sponges or soft bristle brushes.
- Glass must be cleaned periodically to prevent its contamination
- During construction handle glass carefully to prevent contamination and stains.
- Clean glass with water while and after the construction stage to prevent scratches, stains and impurities.
- Use high pressured water to clean the door or window. For a thorough cleaning use sponges or soft bristle brushes.
- It is recommended to use soft soap and water for the cleaning routine. Clean the glass surface with a rag or sponge and the cleaning solution. then wipe the glass with a rag, sponge or window cleaner.
- Reflective glass panels must be clean carefully to prevent any damage, Reflective glass is more vulnerable to damage.
- Reflective glass panels should be cleaned every four months .



Avoid use of metal blades, sandpaper, abrasive sponges or spatula; glass surface could be damaged by those implements.

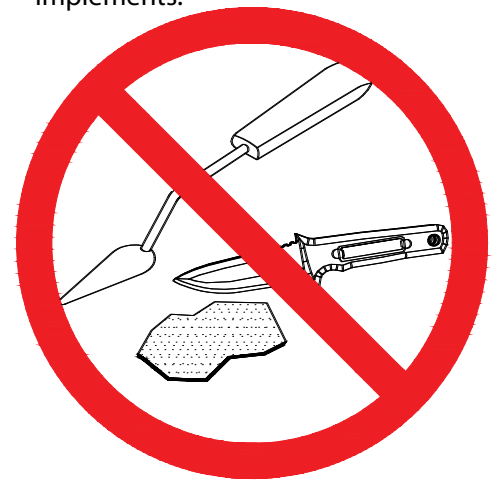

ACCESSORIES MAINTENANCE

- In order to extend service life, it is recommended to clean weather-stripping and screws bi-monthly.
- Soft soap and water should be used for the cleaning process.
- Weather-stripping should be replaced when crystallized or broken.
- Check for missing screws. If all screws are in place, check the silicone seal around them.



Avoid cleaning the gaskets with grease or petrolatum jelly, this causes deterioration.



Periodically inspect the state of all piles and foams. Avoid removing them when cleaning the sill or the head of the frame. They should not be removed for aesthetic reasons as they affect the functionality of the product. Replace them only if necessary.

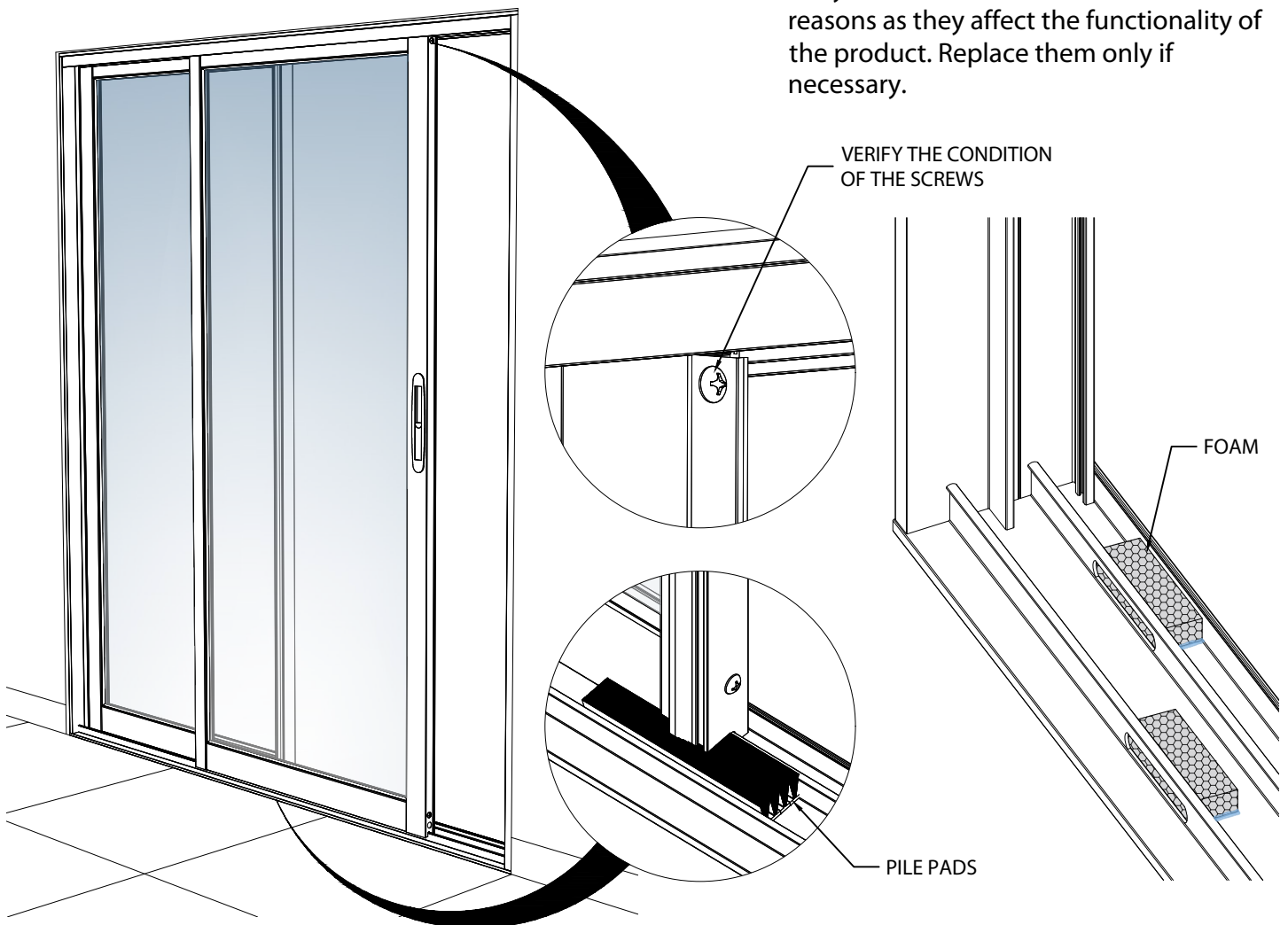







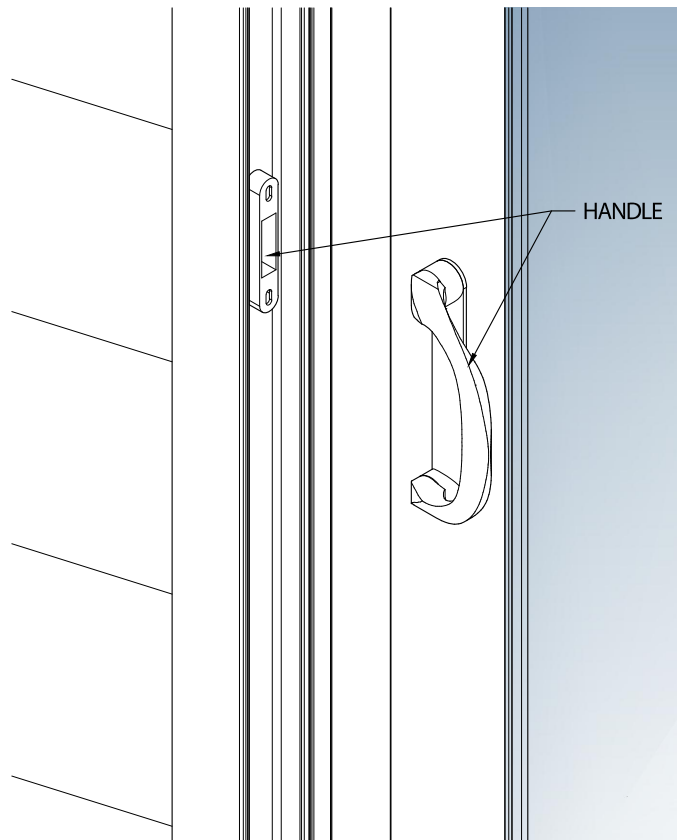
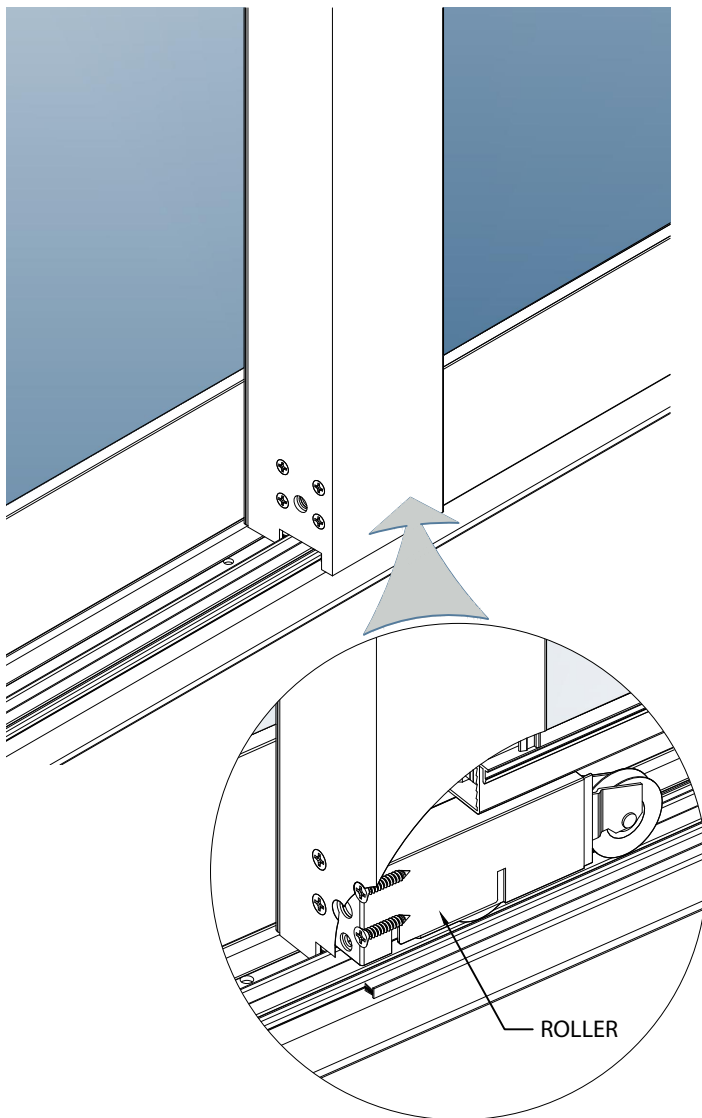

- It is recommended to check rollers once every four months or at any sign of malfunction.
- Handles must be checked once every two months.
- Clean with water and rinse with a soft cloth to remove dust particles or construction residues. Verify correct functionality and change damaged parts.



Avoid cleaning weather-stripping with products derived from petroleum, this might speed up decay.



VERIFY THAT ALL ACCESSORIES, PILES, SEALS, AND SCREWS ARE IN GOOD CONDITION. INSPECT THE SYSTEM TO GUARANTEE ACCORDANCE WITH THE INSTALLATION INSTRUCTIONS.

REVIEW No.	DATE	DESCRIPTION	PAGE
	08-09-2015	Maintenance every six months changed to every four months. Glass maintenance updated.	2
	23-02-2018	Gasket protection with masking tape step while removing panel was included.	4
	05-08-2022	Pile pads inspection note added.	5
	09-03-2023	Accessories maintenance updated.	6
	31-05-2023	Accessories inspection note added.	7
	12-04-2024	Format update.	All
	06-08-2024	PVC care and cleaning instructions are added.	4
	14-02-2025	The maintenance period of the slices is changed from 6 months to 4 months.	7
	28-10-2025	Updated the description of the pressurized water cleaning system.	3,5

12400 SW 134th Court Ste 14, Miami, FL 33186
info@esriimpact.com,
Phone: (+1) 305 489 1608